



COMPETITION

4" & 6" SUSPENSION LIFT

TOYOTA LANDCRUISER & NISSAN PATROL

PRODUCT GUIDELINES



Guidelines for sale and recommendation of 4" (100mm) and 6" (150mm) Lifts for Toyota Landcruiser 80/105, Nissan Patrol GQ, GU.

It is suggested that these Suspension Lift Kits only be installed by competent mechanics with experience in such vehicle modifications.

Installation of these lift kits should NOT be performed when:

- A) The fitter does not have sufficient experience or training.
- B) The fitter does not have the necessary, equipment, tools, including alignment and measuring tools.
- C) The fitter is restricted for time.
- D) No suitable alternative transport is available.

It should be noted that lifts of this nature do bring with the possibility of variables which can and do require modification work to be completed. Not all vehicles will result in the same outcome.

Coil Springs

Raise the suspension ride height by the suggested amount. Additional accessories such as Bullbar, Winch, Long Range Tank, Roofracks, Rear Wheel Carriers, Luggage, Occupants, Larger Spare Wheels, Tool Boxes, Drawer Systems, Recovery Equipment, Steel Trays, may alter the outcome.

Lifts quoted are based upon original factory weighted vehicles.

It must be noted that with larger lifts, a small lean or weight discrepancy will affect the rake and yaw of the vehicle more than with a smaller lift. A cause for a 10mm lean in a 50mm lift vehicle would create approximately 15mm-20mm lean in a vehicle with 6" lift.

Shock Absorbers

41mm Bore and Piston, Foam Cell Type, with Rubber Bushes.

Shock Absorbers are matched in length, available specifically for 4" (100mm) and 6" (150mm) lifts.

Shock Absorbers should only be matched with Coil Springs as specified in the catalogue for the same lift.

For vehicle lifts above 3" (75mm) special alignment components are required.





Alignment Components

Designed specifically for use in vehicle which lift is 4" (100mm) to 6" (150mm). the following components should be used within this range in order to successfully maintain a geometrically correct suspension system.

CASTER PLATES OR BUSHES

PANHARD RODS

SWAY BAR EXTENSION BRACKETS AND LINKS

EXTENDED BRAKE LINES

EXTENDED DIFF BREATHER HOSES

Caster Correction

Vehicles may need to be tested for alignment after lift has been completed but prior to caster correction installation.

Some vehicles may require more or less than others.

- Ironman Caster Correction Bushes can provide 2 - 3.5 degrees of correction.
- Ironman Caster Plates can provide 5 degrees of correction.

* A general rule: For every 25mm (1") of lift, results in approx. 1 degree reduction in caster.

Adjustable Panhard Rods

Used to adjust the sideward axle shift after the vehicle has been raised. Setting adjustment must be completed carefully whenever ride height is changed.

Extended Sway Bar Brackets

Used to lengthen the linking attachment of the Sway bar to chassis. Lifting the vehicle beyond 3" (75mm) requires their use, otherwise damage to the sway bar or chassis can occur together with unsafe vehicle handling.

Brake Hoses

Brake Lines may not have sufficient length to allow for the increased wheel droop allowed by the longer shock absorbers. *Longer Diff Breather Hoses may be needed for the same reasons.

Installing Extended Brake Lines should only be performed by a brake specialist.

Gearbox Spacers

Not used by default in ironman Kits, but can be used to lower the gearbox crossmember to acheive more desirable driveline angles after raising suspension. Each vehicle can differ in requirement. Can also be used on smaller lifts from 40mm+.

Spring spacers

Not used by default in ironman Kits, but can be used to trim the vehicle ride height by 15mm or 30mm.

SPECIFICATIONS



NISSAN PATROL

Coil springs

Part	Free Height (mm)	Thickness (mm)	Rate N/mm	Rate lbs
NISS026B	484 / 469	18	48	273
NISS027B	535 / 521	20	53	301
NISS043B	525 / 510	19	48	273
NISS044B	590 / 575	21	50	284

Shock Absorbers

Part	Lmax (mm)	Lmin (mm)
24091LFE	557	327
24094LFE	718	425
24091LFE1	597	362
24094LFE1	760	460

TOYOTA LANDCRUISER

Coil springs

Part	Free Height (mm)	Thickness (mm)	Rate N/mm	Rate lbs
TOY012C	515 / 520	19	49	280
TOY013C	490 / 497	20	57	324
TOY060B	614 / 622	20	44	250
TOY061B	627 / 637	21	43	244

Shock Absorbers

Part	Lmax (mm)	Lmin (mm)
24683LFE	670	385
24682LFE	670	393
24683LFE1	730	415
24682LFE1	730	423

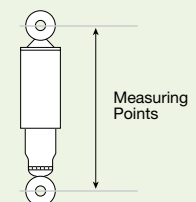
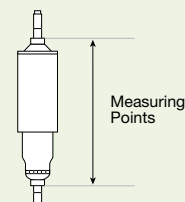
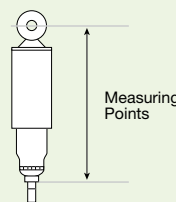
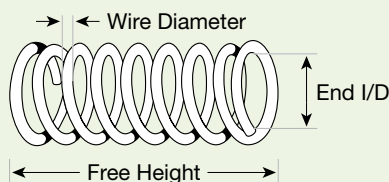



SAFETY WARNINGS

Ironman Suspension products are intended to improve off-road performance. Modifying your vehicle for off-road use may result in the vehicle handling differently than a factory equipped vehicle.

Extreme care must be used to prevent loss of control or vehicle rollover. Failure to drive your modified vehicle safely may result in serious injury or death. Ironman Suspension does not recommend the combined use of suspension lifts, body lifts, or other lifting devices.

Always drive your modified vehicle at reduced speeds to ensure your ability to control your vehicle under all driving conditions.

PRE-INSTALLATION WARNINGS

1. Special literature required: OE Service Manual for model/year of vehicle. Refer to manual for proper disassembly/reassembly procedures of all components.
2. Adhere to recommendations when replacement fasteners, retainers and keepers are called out in the OE manual.
3. Larger rim and tyre combinations may increase leverage on suspension, steering, and related components. When selecting combinations larger than OE, consider the additional stress you could be inducing on the OE and related components.
4. Post suspension system vehicles may experience drive line vibrations. Angles may require tuning, slip joints on shaft may require replacement, shafts may need to be lengthened or trued, and universal joints may need to be replaced.
5. Secure and properly block vehicle prior to installation of Ironman Suspension components.
6. Always wear safety glasses when using power tools.
7. Due to payload options and initial ride height variances, the amount of lift is a base figure.

Final ride height dimensions may vary in accordance to original vehicle attitude. Always measure the attitude prior to beginning installation.

POST-INSTALLATION WARNINGS

1. Check all fasteners for proper torque settings. Check to ensure for adequate clearance between all rotating, mobile, fixed, and heated members.

Verify clearance between exhaust and brake lines, fuel lines, fuel tank, floor boards and wiring harness.

Check steering gear for clearance. Test and inspect brake system.

2. Perform steering sweep to ensure front brake hoses have adequate slack and do not contact any rotating, mobile or heated members.

Inspect brake hoses and breathers at full extension for adequate slack. Failure to perform hose check/replacement may result in component failure. Longer replacement hoses, if needed can be purchased for selected models.

3. Perform head light check and adjustment.

4. Torque check all fasteners after 500km.

Always inspect fasteners and components during regular servicing.

CASTER BUSHES



1144 Castor Bush Kit
 Installation Instructions
 Standard / 2.5 Degree / 3.5 Degree
 Offset Radius Arm Bushes
 Toyota Landcruiser 78, 79, 80, 105 Series
 Nissan Patrol GQ, GU

READ AND UNDERSTAND ALL INSTRUCTIONS AND WARNINGS PRIOR TO INSTALLATION OF SYSTEM AND OPERATION OF VEHICLE.

SAFETY WARNING

Ironman Suspension recommends this system be installed by a professional technician. In addition to these instructions, professional knowledge of disassembly/reassembly procedures and post installation checks must be known and carried out.

IRONMAN KIT INSTALLATION

5. Using a hydraulic workshop press, remove original bushes from arm.

Always wear eye protection when working with hand tools and machinery.

6. Carefully align Ironman bushes to desired offset (see image)

7. Do not grease the outside of the Ironman Bush, however, do grease the inside in which the tube is fitted.

8. Press or tap in Ironman Bushes carefully making sure the positioning of the bolt holes is correct. The centre to centre measurement is (Toyota 185mm) (Nissan 240mm) (see image)

9. Refit arm to vehicle, but do not fully tighten at this stage, fit bolts finger tight only.

10. When both arms completed, carefully lower the vehicle to ground. Bounce the vehicle to settle the suspension.

11. Use thread locking agent on threads, and torque all bolt mounts to manufacturer's specifications.

12. Check all fasteners for proper torque.

13. The vehicle will require a front end alignment.

14. Check all fasteners after initial drive and again in 500km.

PARTS LIST

Part #	Description	Qty
1144UT	Polyurethane Half Bush	8
	Steel Tube	4

KIT INSTALLATION

1. Mark original Radius arm bushes and arm with a line indicating a vertical line 90 deg. to the level ground.

2. Safely raise the vehicle and support with jack stands for safety.

• **Ensure all new components received are correct before removal of existing parts.**

COMPONENT REMOVAL

3. Support differential with floor jack to prevent damage to brake hoses from over stretching.

4. Carefully unbolt front radius arm and remove from vehicle. It may be necessary to remove track rod and stabilizer bar in Nissan vehicles.

RAISED VEHICLE 3"-4"
 3.5 DEGREE OFFSET

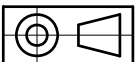
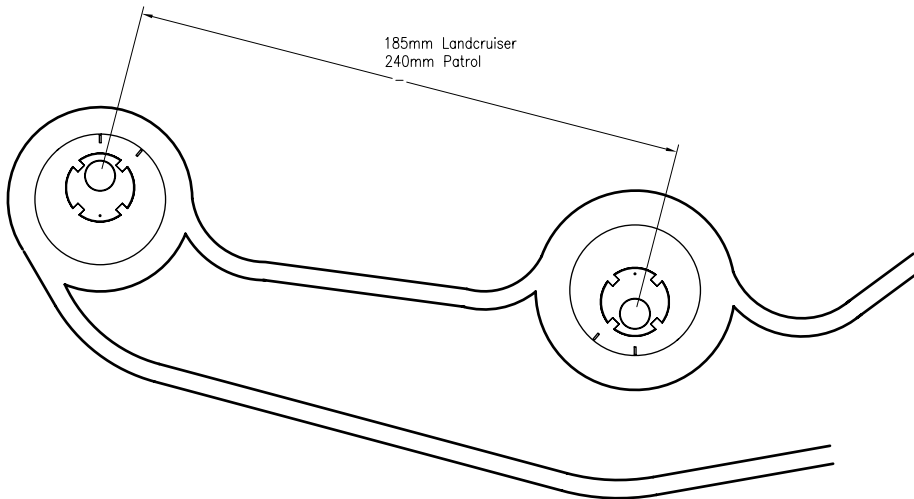

IRONMAN SUSPENSION		
TITLE 1144UT BUSH		
DATE	DRAWING NO.	SHEET SIZE
SCALE NTS		

Corner Westall & Centre Roads, Clayton, Victoria, 3168.
 Telephone: 1300 731 137



CASTER PLATES

TOYOTA LANDCRUISER

80, 105 Series
5 Degree Caster Plates
For 130mm - 170mm Lifts

- Ensure you have received all parts prior to commencement of work.
- Work on one Radius Arm at a time.
- Three Caster Plates will appear similarly shaped. One will appear different, the odd plate must be installed to inner side nearest enlarged diff casing.

1) Remove both bolts from radius arm/diff mount. Then position caster plates with 1/2 cut washer facing inward, loosely install and lightly tighten new rear bolt and nut to hold assembly in place.

2) Raise front of caster plates so the 1/2 cut washer is butted up against bottom of diff mount brackets, it is required to grind away the diff bracket at this point, until the front upper hole in caster plate is in line with upper hole in diff bracket.

3) Loosen rear radius arm bolt and remove front bolt on the other side of vehicle to aid diff movement and positioning. Return to caster plate assembly and install new front lower bolt, followed by front upper bolt including spacer tube between diff mounts.

4) Only tighten assembly after vehicle has been lowered to the ground.

5) Wheel align vehicle, and check tension of all bolts after 500km.



IRONMAN 4X4
CNR CENTRE AND WESTALL RD
CLAYTON, VICTORIA, AUSTRALIA, 3168
PH: +61 3 9532 1111
WWW.IRONMAN4X4.COM

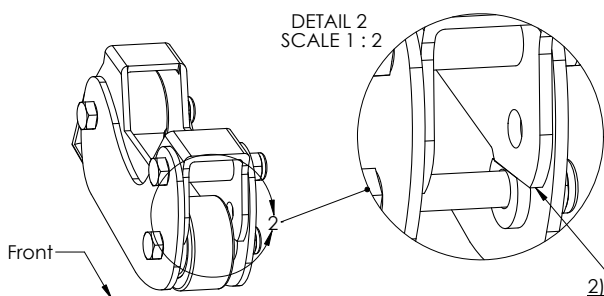

Some image detail has been omitted for clarity

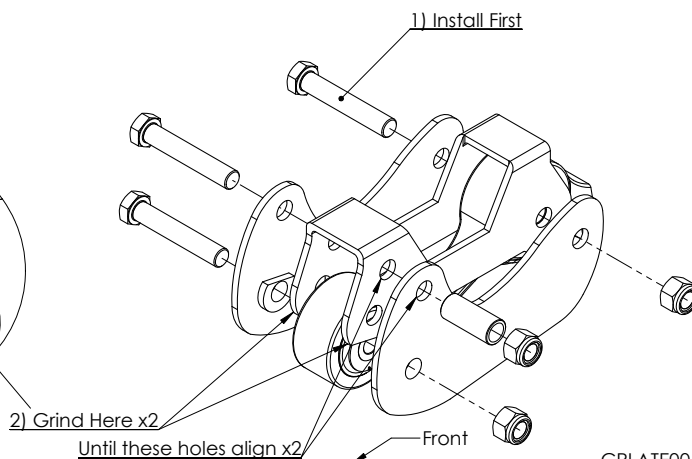

CPLATE001

NISSAN PATROL

GQ, GU Series with Coil Springs
5 Degree Caster Plates
For 130mm - 170mm Lifts

- Ensure you have received all parts prior to commencement of work.
- Work on one Radius Arm at a time.
- Three Caster Plates will appear similarly shaped. One will appear different, the odd plate must be installed to inner side nearest enlarged diff casing.

1) Remove both bolts from radius arm/diff mount. Then position caster plates with 1/2 cut washer facing inward, loosely install and lightly tighten new rear bolt and nut to hold assembly in place.

2) Raise front of caster plates so the 1/2 cut washer is butted up against bottom of diff mount brackets.

2a) Use vice grips to clamp, then run a small tack weld along the edge of the caster plates and diff bracket to firmly secure caster plates into position, checking again that the 1/2 cut washer is butted firmly against diff bracket.
 *Remember to disconnect the battery before welding on vehicle.

3) Using the front upper hole on the caster plates as a guide, drill into the diff mount.

3a) Use a 16.5mm drill bit, and a right angle drill for best results.

4) Loosen rear radius arm bolt and remove front bolt on the other side of vehicle to aid diff movement and positioning. Return to caster plate assembly and install new front lower bolt, followed by front upper bolt including spacer tube between diff mounts.

5) Only tighten assembly after vehicle has been lowered to the ground.

6) Wheel align vehicle, and check tension of all bolts after 500km.



IRONMAN 4X4
CNR CENTRE AND WESTALL RD
CLAYTON, VICTORIA, AUSTRALIA, 3168
PH: +61 3 9532 1111
WWW.IRONMAN4X4.COM

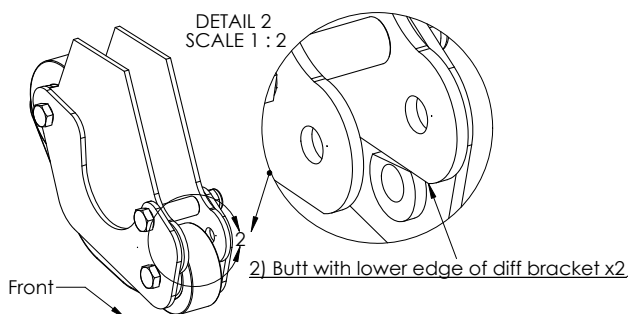

Some image detail has been omitted for clarity

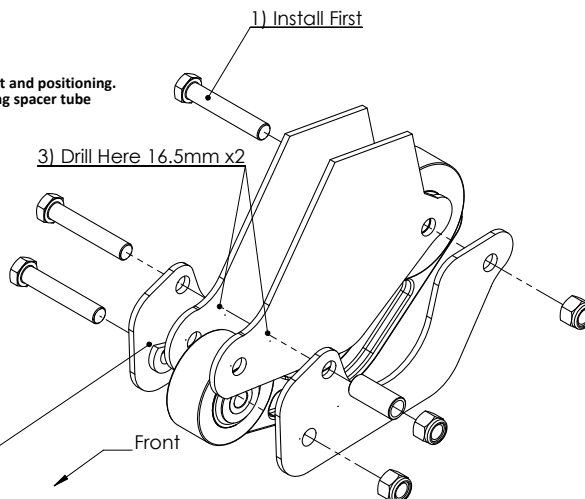

CPLATE003



VICTORIA

Cnr Centre & Westall Roads,
Clayton, Victoria 3168 Australia

QUEENSLAND

1 Hinkler Court,
Brendale, Queensland 4500 Australia

1300 731 137

www.ironman4x4.com

sales@ironmansuspension.com